



RANGE OF PERFORMANCE

Flow rate up to 90 l/min (5.4 m³/h)
Head up to 100 m

LIMITS OF USE

Manometric suction lift up to 8 m
Liquid temperature up to + 60°C
Environment temperature up to + 40°C

CONSTRUCTION AND SAFETY STANDARDS

EN 60 335-1
IEC 335-1
CEI 61-150

EN 60034-1
IEC 34-1
CEI 2-3



INSTALLATION AND USE

They are recommended for pumping clean water without abrasive particles and liquids that are chemically non aggressive to the materials from which the pump is made.

FOR THEIR RELIABILITY, SIMPLICITY OF USE AND ECONOMY THEY ARE SUITABLE FOR DOMESTIC USE AND IN PARTICULAR FOR DISTRIBUTING WATER IN COMBINATION WITH SMALL PRESSURE SETS, FOR IRRIGATING GARDENS.

The pumps must be installed in enclosed places, or at least protected against inclement weather.

GUARANTEE 2 YEARS subject to our general terms of sale.

CONSTRUCTION CHARACTERISTICS

- **PUMP BODY:** cast iron, with threaded ports ISO 228/1.
 - **MOTOR BRACKET (patent n° 1289150):** aluminium with brass insert; reduces starting difficulties due to seizure of the impeller after long periods of inactivity.
 - **IMPELLER:** brass, of the type with radial peripheral vanes.
 - **MOTOR SHAFT:** stainless steel EN 10088-3 - 1.4104.
 - **MECHANICAL SEAL:** ceramic - graphite - NBR.
 - **ELECTRIC MOTOR:** the pumps are close-coupled to a carefully matched PEDROLLO electric motor, quiet running, totally enclosed fan cooled (TEFC), suitable for continuous duty.
- PKm:** single-phase 230 V - 50 Hz with capacitor and thermal overload protector.
PK: three-phase 230/400 V- 50 Hz.
- **INSULATION:** class F. ● **PROTECTION:** IP 44.
 - **REGISTERED MODEL n° 72753.**
 - **PKm 60® is a REGISTERED TRADE MARK n° 602636.**

OPTIONS ON REQUEST

- ⇒ special mechanical seal
- ⇒ other voltages or frequency 60 Hz

CURVES AND PERFORMANCE DATA AT n= 2900 1/min

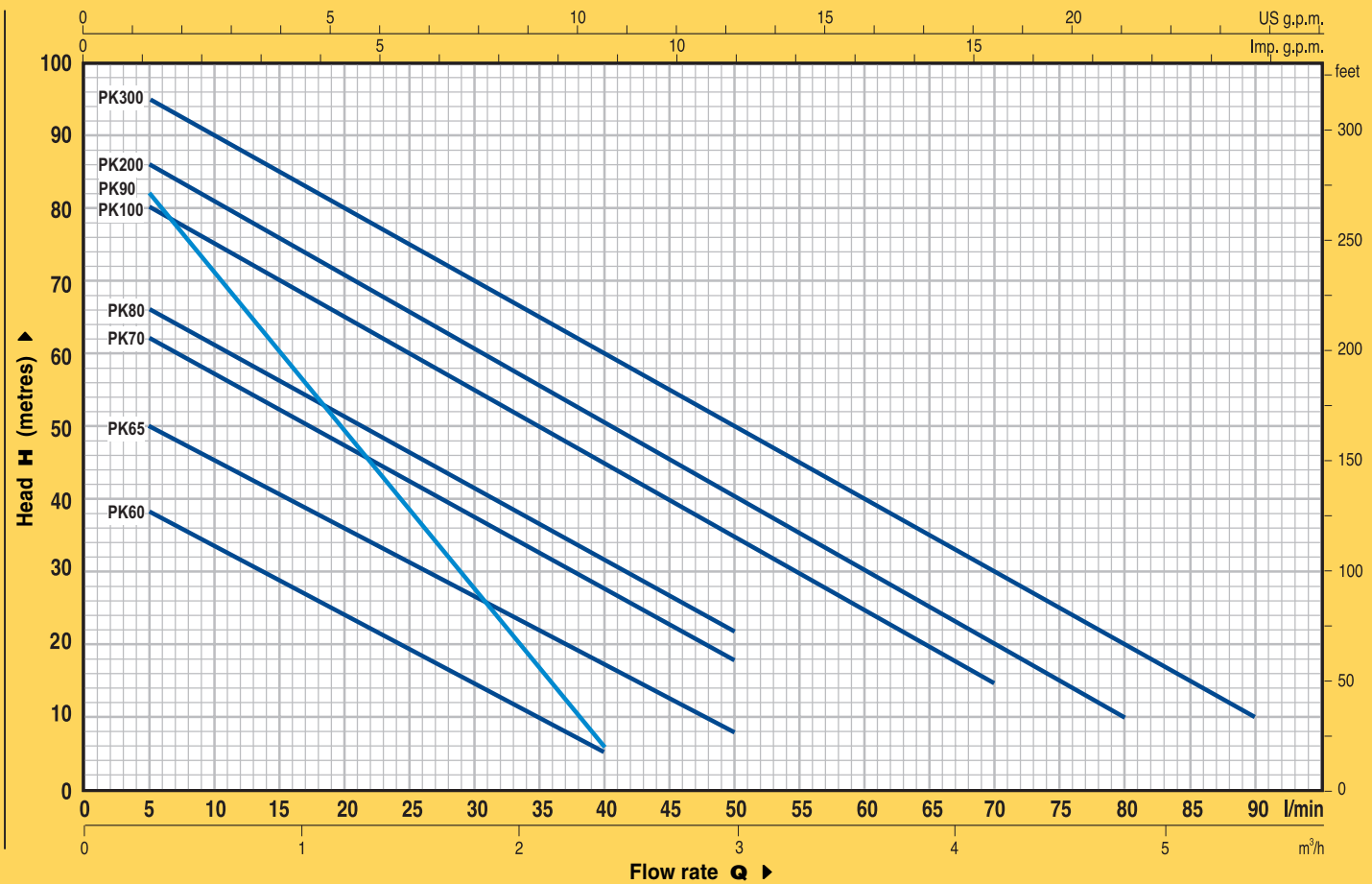

TYPE		POWER		Q	m³/h																
Single-phase	Three-phase	kW	HP		0	0.3	0.6	0.9	1.2	1.5	1.8	2.1	2.4	3.0	3.6	4.2	4.8	5.4			
PKm 60®	PK 60®	0.37	0.50	l/min	0	5	10	15	20	25	30	35	40	50	60	70	80	90			
PKm 65	PK 65	0.50	0.70	H metres	40	38	33.5	29	24	19.5	15	10	5								
PKm 70	PK 70	0.60	0.85		55	50	45.5	40.5	36	31	27	22	17	8							
PKm 80	PK 80	0.75	1		65	62	57	52	47	42	37	32	27	18							
PKm 90	PK 90	0.75	1		70	66	61	56	51	46	41	36.5	31	22							
PKm 100	PK 100	1.1	1.5		90	82	71	60	49	38	27	17	5								
PKm 200	PK 200	1.5	2		85	80	75	70	65	60	55	50	45	35	25	15					
—	PK 300	2.2	3		90	86	81	76	71	65.5	60	55	50	40	30	20	10				
					100	95	90	85	80	75	70	65	60	50	40	30	20	10			

Q = Flow rate H = Total manometric head

Tolerance of the performance curves according to EN ISO 9906 App. A.

DIMENSIONS AND WEIGHTS

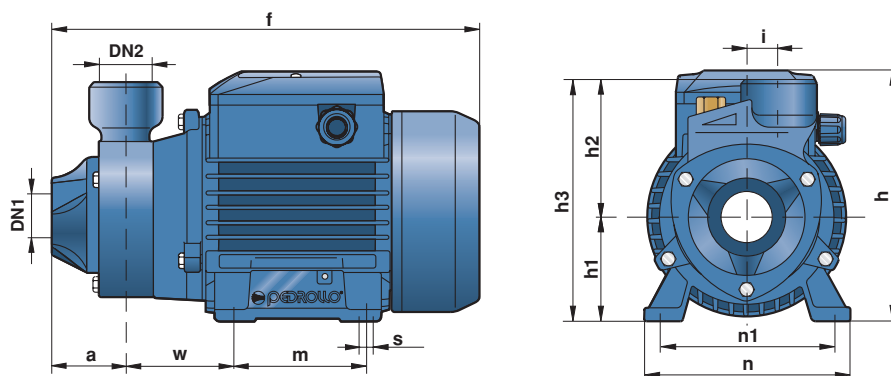

TYPE		PORTS		DIMENSIONS mm												kg		
Single-phase	Three-phase	DN1	DN2	a	f	h	h1	h2	h3	i	m	n	n1	w	s	1~	3~	
PKm 60®	PK 60®	1"	1"	42	243	152	63	75	138	20	80	120	100	55	7	5.3	5.3	
PKm 65	PK 65			48	258/250			80	143							7.7	6.4	
PKm 70	PK 70			55	285	179	71	85	156							10.1	9.2	
PKm 80	PK 80			58	288			95	166							10.3	9.9	
PKm 90	PK 90	3/4"	3/4"															
PKm 100	PK 100	1"	1"									100	158	125	85	9	15.0	13.1
PKm 200	PK 200			55	348	212	80	94	174		16.0						15.2	
—	PK 300																18.0	